

DEPARTMENT OF THE ARMY TECHNICAL BULLETIN

**GUIDE TO CONVENTION FOR SAFE CONTAINERS (CSC)
REINSPECTION OF MODULAR CAUSEWAY SYSTEMS (MCS) ISOPAK
COMPONENTS**

NSN: 1945-01-398-3856 1945-01-473-2282
1945-01-473-2162 1945-01-497-7059
1945-01-505-1665 1945-01-473-2285
1925-01-502-8772



DISTRIBUTION STATEMENT A – Approved for public release; distribution is unlimited.

HEADQUARTERS, DEPARTMENT OF THE ARMY

JULY 2008

LIST OF EFFECTIVE PAGES

NOTE: Zero in the "Change No." column indicates an original page or work package.

Date of issue for the original manual is:

Original 31 July 2008

TOTAL NUMBER OF PAGES FOR FRONT AND REAR MATTER IS 20 AND TOTAL NUMBER OF PAGES IS 44, CONSISTING OF THE FOLLOWING:

Page	Change No.	Page	Change No.
Front Cover	0	Blank	0
Blank	0	Metric Conversion Chart	0
List of Effective Pages	0	Pin Page	0
i-iv	0		
1	0		
Blank	0		
3	0		
4	0		
5	0		
6	0		
7	0		
8	0		
9	0		
10	0		
11	0		
Blank	0		
A-1/(A-2 Blank)	0		
Blank	0		
Appendix B Title Page	0		
Blank	0		
B-1	0		
B-2	0		
B-3	0		
B-4	0		
B-5	0		
B-6	0		
B-7	0		
B-8	0		
2028 Instruction Page	0		
Blank	0		
Sample 2028	0		
Sample 2028	0		
Blank 2028	0		
Blank 2028	0		
Blank 2028	0		
Blank 2028	0		
Authentication Page	0		

HEADQUARTERS
DEPARTMENT OF THE ARMY
WASHINGTON, D.C., 31 July 2008

TECHNICAL BULLETIN

**GUIDE TO CONVENTION FOR SAFE CONTAINERS (CSC)
REINSPECTION OF MODULAR CAUSEWAY SYSTEMS (MCS)
ISOPAK COMPONENTS**

NSN: 1945-01-398-3856 1945-01-473-2282
1945-01-473-2162 1945-01-497-7059
1945-01-505-1665 1945-01-473-2285
1925-01-502-8772

REPORTING ERRORS AND RECOMMENDING IMPROVEMENTS

You can help improve this publication. If you find any errors, or if you would like to recommend any improvements to the procedures in this publication, please let us know. The preferred method is to submit your DA Form 2028 (Recommended Changes to Publications and Blank Forms) through the Internet, on the Army Electronic Product Support (AEPS) website. The Internet address is <https://aeprs.ria.army.mil>. The DA Form 2028 is located under the Public Applications section in the AEPS Public Home Page. Fill out the form and click on SUBMIT. Using this form on the AEPS will enable us to respond quicker to your comments and better manage the DA Form 2028 program. You may also mail, e-mail, or fax your comments or DA Form 2028 directly to the U.S. Army TACOM Life Cycle Management Command. The postal mail address is U.S. Army TACOM Life Cycle Management Command, ATTN: AMSTA-LC-LMPP / TECH PUBS, 1 Rock Island Arsenal, Rock Island, IL 61299-7630. The e-mail address is tacomlcmc.daform2028@us.army.mil. The fax number is DSN 793-0726 or Commercial (309) 782-0726.

Distribution Statement A: Approved for public release. Distribution is unlimited.

TABLE OF CONTENTS

	<u>Page No.</u>
Foreword.....	1-2
General.....	3-4
Container Inspection Criteria.....	5-10
Container Inspection Procedures.....	10-12
Appendix A: Modular Causeway CSC Inspection Checklist.....	A-1-A-2
Appendix B: Construction Diagrams of Causeway Modules	
Robishaw and Oldenburg Lake Shore (Title Page)	
Robishaw Intermediate Module.....	B-1
Robishaw Center Rake Module.....	B-2
Robishaw Left Rake Module.....	B-3
Robishaw Right Rake Module.....	B-4
Lake Shore Intermediate Module.....	B-5
Lake Shore Center Rake Module.....	B-6
Lake Shore Left Rake Module.....	B-7
Lake Shore Right Rake Module.....	B-8

Army Modular Causeway Systems ISOPAK Components CSC Re-inspection Process

FOREWORD

In accordance with AR 56-4 paragraph 3.3, intermodal configured modular systems must meet regulatory requirements to include CSC certification. In conformance with 49 CFR 452, in order to maintain CSC certification and ensure continued safe handling and transportability in the commercial intermodal transport environment, the intermodal configured modules must be periodically examined. In accordance with DOD 4500.9-R DEFENSE TRANSPORTATION REGULATION PART VI, All ISO containers (ISOPAK's are classified as ISO containers for purposes of intermodal movement) that move in the Defense Transportation System (DTS) must be certified to meet 49 CFR and CSC/46 U.S.C. app. 1503 standards. This Modular Causeway Systems (MCS) reinspection program endeavors to comply with these directives and ensure that no injury to personnel or damage to property occurs from structural failure or deficiency.

This document provides reinspection criteria and procedures to be used when visually examining MCS ISOPAK components. The criteria and procedures contained herein enable personnel to identify MCS components that are serviceable and safe for intermodal loading and shipping.

This document applies to any commercially owned or military owned Modular Causeway Component System meeting the standards of the International Organization for Standardization (ISO) and certified under the provisions of the International Convention for Safe Containers (CSC). This document is specifically used worldwide by civilians and military personnel responsible for inspecting and selecting serviceable MCS Components for shipment of Department of Defense (DOD) materiel.

This document provides a variety of helpful illustrations. Beneficial comments (recommendations, additions, deletions), and any other pertinent data that may be of use in improving this document, should be addressed to: Commander, U.S. Tank Automotive Armaments Command; ATTN: Program Executive Office Combat Support and Combat Service Support (PEO CS& CSS), Warren Michigan 48397-5000; or by letter.

1. GENERAL

1.1 Purpose

This document provides inspection criteria and procedures when visually examining MCS Components. Following the criteria and procedures contained herein will enable personnel to identify MCS Components that are serviceable and safe for loading and shipping. MCS is constructed of many different components, the inspection of each component is to recertify that they may be used in an ISOPAK or identify the component as unserviceable.

NOTE: This document is not to be used as the standard for performing container repairs.

1.2 Scope

This document applies to the selection of any commercially owned or military owned MCS components meeting the standards of the International Organization for Standardization (ISO), and certified under the provisions of the International Convention for Safe Containers (CSC). This document is specifically used worldwide by civilians and military personnel responsible for inspecting and selecting serviceable MCS components for shipment of Department of Defense (DOD) materiel.

Nomenclature: Causeway Ferry (CF)

NSN: 1945-01-398-3856

LIN: M90110

Model Number: None

ACAT Level: III

Density: Three (3)

Nomenclature: Floating Causeway (FC-1)

NSN: 1945-01-473-2162

LIN: C14504

Model Number: None

ACAT Level: III

Density: Two (2)

Nomenclature: Floating Causeway (FC-2)

NSN: 1945-01-505-1665

LIN: C14504

Model Number: None

ACAT Level: III

Density: One (1)

Nomenclature: Roll-on/Roll-off Discharge Facility (RRDF-1)

NSN: 1945-01-473-2282

LIN: C14572

Model Number: None

ACAT Level: III

Density: Two (2)

Nomenclature: Roll-on/Roll-off Discharge Facility (RRDF-2)

NSN: 1945-01-497-7059

LIN: C14572

Model Number: None

ACAT Level: III

Density: Four (4)

Nomenclature: Warring Tug (WT-1)

NSN: 1945-01-473-2285

Model Number: None

ACAT Level: III

LIN: W41775

Density: Seven (7)

Nomenclature: Warring Tug (WT-2)

NSN: 1925-01-502-8772

Model Number: None

ACAT Level: III

LIN: W41775

Density: Nine (9)

1.3 Objective

Inspecting personnel will use this document to cause:

- a. Inspection standardization among DOD agencies for acceptability of MCS modules owned by the DOD.
- b. Preparation of inspection reports that are properly annotated to reflect MCS component condition and reason(s) for rejection; and
- c. Compliance with international treaties, conventions, and United States transportation law.

2. CONTAINER INSPECTION CRITERIA

2.1 General Requirements

2.1.1 Regulatory Mandates: An MCS ISOPAK may not be offered for the carriage of any type unless the container is structurally serviceable as evidenced by a valid CSC Safety Approval Plate and verified by a detailed visual examination. The CSC Safety Approval Plate and the visual examination must conform to the mandates of 49 CFR, parts 451 and 452. Furthermore, if the MCS has any Hazardous Material, it must meet specific structural serviceability requirements as prescribed by the IMDG Code and mandated by 49 CFR Part 176.172. If an MCS has any safety related deficiency or damage that could place any person in danger, it will not be used.

2.1.2 Markings and Data Plates: Each MCS module must bear a legible and valid CSC Safety Approval Plate marked in accordance with CSC format requirements. The CSC Safety Approval Plate will be securely affixed at a readily visible place on the MCS, where it is not easily damaged. All maximum gross weight markings on the manufacturer's data plate must be consistent with the maximum gross weight marking on the CSC Safety Approval Plate. No ISOPAK is constrained by specific serial numbers; each component/module is a stand-alone unit that may be configured into an ISOPAK. An ISOPAK is defined as a group of components, when assembled, meets the ISO dimensional requirements for an intermodal container.

2.1.3 Configuration: Any distortion of the overall configuration great enough to preclude proper engagement of handling/lifting equipment, mounting and securing on chassis, vehicle, or aircraft pallet, or insertion into the cell of a ship is unacceptable. Side-to-side connector castings may protrude beyond the ISO envelope by not more than 3/8. The external dimensions must conform to the tolerances prescribed by ISO standard 668 as depicted in Figure 2 .1.

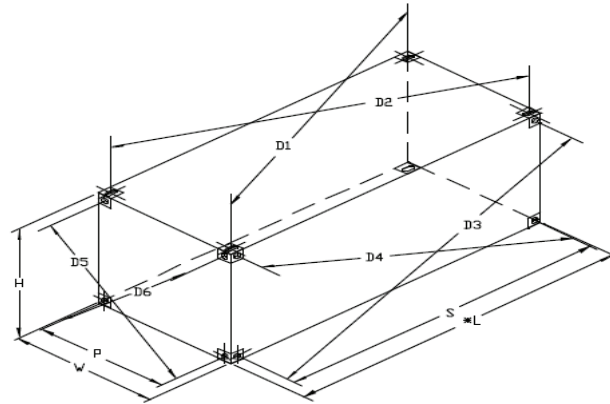

External Dimensions and Tolerances in Millimeters and Feet and Inches								
Nominal Length FT	L (External Length)			S			K 1 MAX.	
	MM	FT	IN	MM	FT	IN	MM	IN
40	12,192 +0 -10	40 0	+0 -3/8	11,985 +6 -6	39	3-7/8 +1/4 -1/4	19	3/4
20	6,058 +0 -6	19 10 1/2	+0 -1/4	5,853 +5 -5	19	2-7/16 +3/16 -3/16	13	1/2

Note: side-to-side connector casting do protrude beyond the ISO envelope by not than 3/8.

	W (External Width)			P			K 2 MAX.	
	MM	FT	IN	MM	FT	IN	M	IN
All Lengths	2,438 +0 -5	8 0	+0 -3/16	2,259 +4 -4	7	4 31/32 +5/32 -5/32	10	3/8

Nominal Length FT	H (Overall Height)		
	MM	FT	IN
9 1/2	2,896 +0 -5	9 6	+0 -3/16
8 1/2	2,591 +0 -5	8 6	+0 -3/16
8	2,438 +0 -5	8 0	+0 -3/16
5 2/3	1,727 +0 -5	5 8	+0 -3/16
4 1/4	1,295 +0 -5	4 3	+0 -3/16

S = LENGTH BETWEEN CENTERS OF CORNER FITTING APERTURES

P = WIDTH BETWEEN CENTERS OF CORNER FITTING APERTURES

D = DISTANCE BETWEEN CENTERS OF APERTURES OF DIAGONALLY OPPOSITE CORNER FITTINGS

K1 = DIFFERENCE BETWEEN D1 AND D2 OR D3 AND D4

K2 = DIFFERENCE BETWEEN D5 AND D6

FIGURE 2.1 ISO DIMENSIONS AND TOLERANCES

2.2 Primary Structural Components: An MCS with any major defect in any component of its primary structure is unacceptable. For purposes of this criterion, primary (main) structural components (members) include: corner fittings, corner posts, top, bottom, and sides.

2.2.1 Acceptable Welding Patterns: MCS are originally deemed suitable for use if they have been given CSC certification by such agencies as the United States Coast Guard (USCG) or USCG appointed agencies. These agencies are highly reputable and bear the liability that the MCS is manufactured in accordance with ISO and CSC requirements. Welding patterns conforming to the original manufacturer's design are, therefore, acceptable. Since welding patterns may vary depending on design and manufacture, inspection should be directed at looking for broken junctures or welded repairs that are not consistent with other corresponding welds of that container.

2.2.2 Acceptable Repairs: For purposes of these criteria, a repair is any repair of a primary structural member that replaces material without complete replacement of the member. Areas repaired by straightening and/or bead welding are not to be construed as splices. Gussets, backup plates or other reinforcement (protector) plates are not to be construed as repairs. An acceptable repair on steel side, bottom, or top is butt-welded, flush fitting and restores the original size and cross-sectional profile of the repaired component. An acceptable repair is a minimum of 6 inches (150mm) long. Both inserts and section (full profile) are acceptable types of repair, but not in all cases. Read inspection criteria of the component for specific repair allowances and IAW applicable repair manuals. If a repair would end within 12 inches (300mm) of another weld, such as at the juncture with the corner fitting, it must be extended to that weld. Backup plates installed on the backside of a splice are permissible if the backup plate extends a minimum of 6 inches (150mm) beyond each end of the repair.

2.2.3 Major Defects:

a. General MCS A major defect includes:

- 1) A crack, break, cut, tear, puncture, or corrosive failure in any primary structural component;
- 2) A missing, cracked, or broken corner fitting;
- 3) A missing, cracked, or broken weld at the juncture between any primary structural components;
- 4) Any outward deformation such as a dent, bend or bow in any primary structural component that is in excess of ISO external dimensional tolerances as depicted in Figure 2.1;
- 5) An improper splice (e.g. less than 6 inches long) in any primary structural component;

6) Any damage to, or degradation within, a structural component which could place any person in danger during subsequent handling, stacking, or transport of the MCS.

b. Hazardous Material:

1) For a powered module which contains any hazardous material, a major defect includes any of the defects listed above, or a dent or bend in any primary structural component that is greater than 3/4 inch (19mm) in depth, regardless of length.

2.2.4 Corner Fittings: Refer to Figure 2.2. Corner fittings must not be distorted or cracked and must not have any worn, broken or gouged apertures that would prevent engagement or safe use of transport securing devices or container lifting devices. No repairs may be performed on a corner fitting.

2.2.5 Corner Posts: Refer to figure 2.3 An MCS module is unacceptable if a corner post has any major defect. (Corner posts are built into the structure of the module)

a. A major defect in a corner post includes:

1) A dent or bend that is greater than 3/4 inch (19mm) in depth, regardless of length;

2) A crack, break, cut, tear, puncture, or corrosive failure;

3) A defective, cracked, or broken weld at the juncture with a corner fitting.

4) Any outward deformation such as a dent, bend, or bow that is in excess of ISO external dimensional tolerances as depicted in Figure 2.1;

5) A splice must not extend through or across more than 1/2 the cross-sectional profile of the post;

6) Any splice in a steel corner post other than a butt-welded insert or full profile splice;

b. Hazardous Material:

1) For a powered module which contains Hazardous Material, a major defect in a corner post includes any of the defects listed above and also any defective splice.

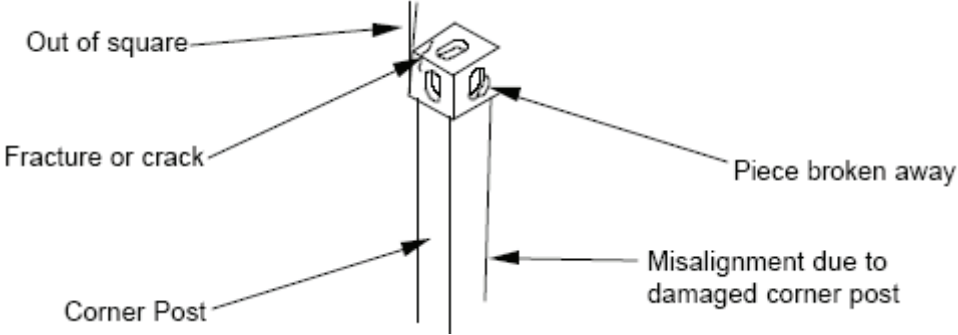

FIGURE 2.2 – CORNER FITTING

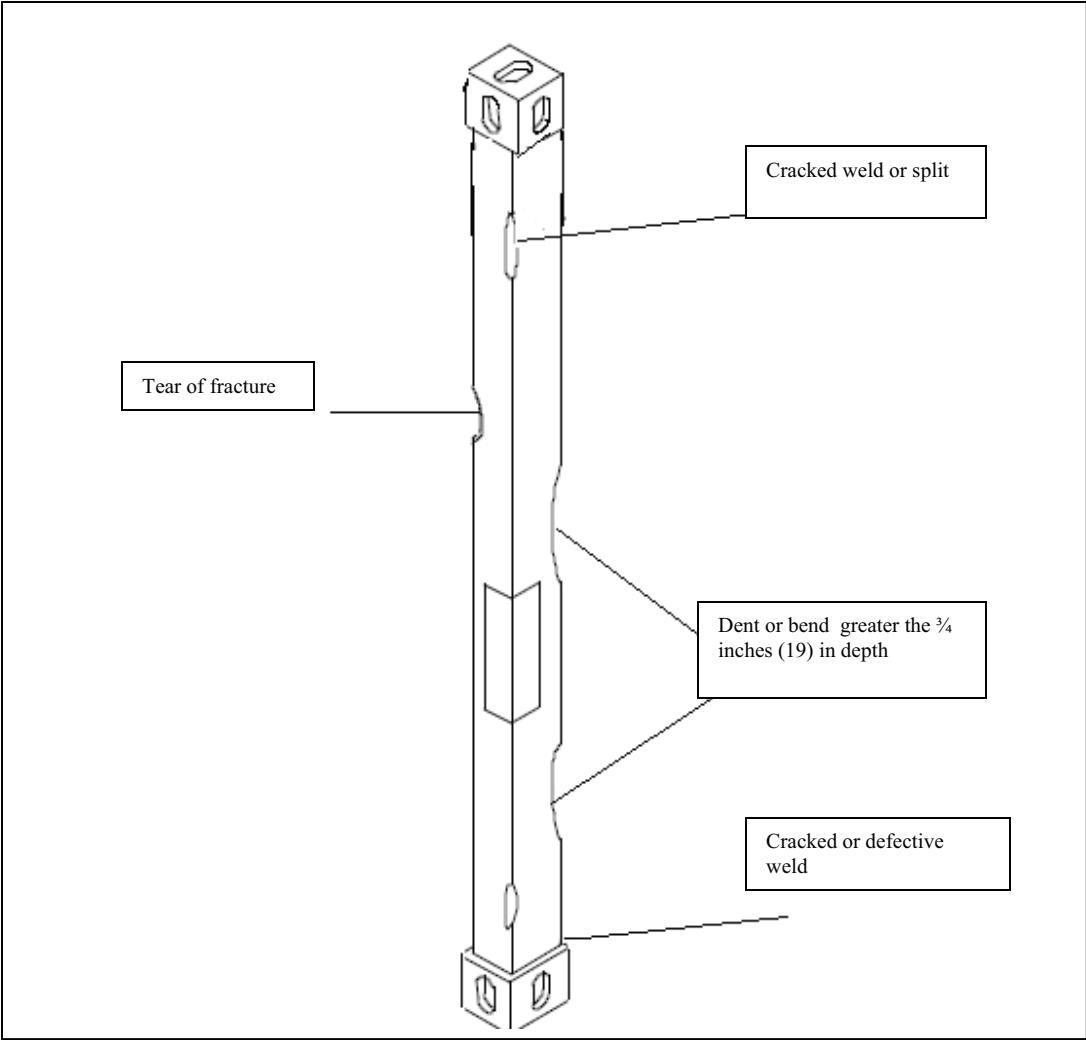

FIGURE 2.3 – CORNER FITTING

2.2.6 Top, Bottom, End (wall) plating, or Sides (TBS). An MCS module is unacceptable if a Top, Bottom, or Side wall has any major defect.

a. Major defects include:

1) A dent or bend in the TBS that is greater than 1-9/16 inch in depth, regardless of length;

2) A crack, break, cut, tear, puncture, or corrosive failure in the TBS;

3) A missing, cracked, or broken weld at the juncture between primary structural components;

4) Any outward deformation such as a dent, bend or bow in any primary structural component that is in excess of ISO external dimensional tolerances as depicted in Figure 2.1;

b. Hazardous Material:

1) For a powered module which contains any Hazardous Material, a major defect includes any of the defects listed above as well as a dent or bend in a top, bottom, or side that is greater than 3/4 inch (19mm) in depth, regardless of length.

3. CONTAINER INSPECTION PROCEDURES

3.1 Prerequisites:

3.1.1 Inspector Qualifications:

a. The CSC re-inspection must be performed by qualified personnel, trained and experienced in the detection of container structural damage.

3.1.2 Judgment of Criteria: The MCS inspection criteria will be met through a visual examination and, except where tolerances are provided, acceptance of the MCS will be based on the judgment of the inspector.

3.2 Suggested Tools and Equipment:

3.2.1 Long Straight Edge: A tautly drawn wire, string, or other form of a long straight edge is needed to determine whether any portion of the MCS (e.g., a side or a top) protrudes past the outside surfaces of the corner fittings.

3.2.2 Measuring Tape (Ruler): A measuring tape (ruler) is required to check dimensional tolerances and MCS alignment.

3.2.3 Welder's Hammer: A welder's hammer is helpful in determining the strength of welds or steel structural components

3.2.4 Ladder: A ladder or other safe means for accessing the top of the MCS is recommended.

3.2.5 Flashlight: A flashlight improves visual acuity, especially during examination of the interior or the recesses of the understructure.

3.2.6 Chalk: Marking (circling) location of defects with chalk as they are discovered facilitates preparation of inspection report and helps maintenance personnel locate areas to be repaired.

3.2.7 Depth Gauge: A device with a straight edge and a point enables inspector to check depth of dents against a designated limit.

3.4 Documents:

3.4.1 Modular Causeway CSC Inspection Checklist: An MCS inspection checklist must be used to ensure complete examination and to indicate acceptance or reason(s) for failure. Appendix A contains the CSC checklist for MCS described in this document. A separate checklist shall be completed for each MCS module. All deficiencies found during inspection should be clearly annotated on the checklist and acceptance or rejection must be indicated, sign and dated. After a CSC reinspection is performed by a qualified inspector and the MCS is found acceptable, the owner will apply/stamp a new date of inspection or a new CSC Safety Approval Plate.





CSC SAFETY APPROVAL			
USA/MC	104/05		
DATE MANUFACTURED			
IDENTIFICATION NO.	SERIAL #: P20LRP		
MAXIMUM GROSS WT.	5670 KG.	12500 LBS.	
ALLOW. STACK. WT. 1.8 G	144000 KG.	317460 LBS.	
RACKING TEST LOAD VALUE	15286 KG.	33700 LBS.	
REINSPECTION DATES	/ /	/ /	/ /
	/ /		
CONFIGURATION TYPES			
			
"A"	"B"	"C"	"D"
			
		"E"	"F"

Figure 2.4 Typical Consolidated Data Plate.

MODULAR CAUSEWAY CSC INSPECTION CHECKLIST
Appendix A

MCS Serial Number				Date of Inspection			
Type of MCS Module		Inspectors Name		(Circle One) Pass Fail		Next Inspection Due Date Month Year	
Installation/Activity							
Front			Right Side			Left Side	
Component		Defects	Component		Defects	Component	
PASS FAIL			PASS FAIL			PASS FAIL	
Corner fitting			Corner fitting			Corner fitting	
Welds			Welds			Welds	
Plate panel			Plate panel			Plate panel	
Corner Post			Corner Post			Corner Post	
CSC Plate			CSC Plate			CSC Plate	
BACK			TOP			BOTTOM	
Component		Defects	Component		Defects	Component	
PASS FAIL			PASS FAIL			PASS FAIL	
Corner fitting			Corner fitting			Corner fitting	
Welds			Welds			Welds	
Plate panel			Plate panel			Plate panel	
Corner Post			Corner Post			Corner Post	
CSC Plate			CSC Plate			CSC Plate	
REMARKS:							

APPENDIX B

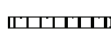
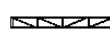
CONSTRUCTION DIAGRAMS OF CAUSEWAY MODULES

ROBISHAW AND OLDENBURG LAKE SHORE

ROBISHAW INTERMEDIATE MODULE
MODULE SERIAL NO. _____ DATE: _____

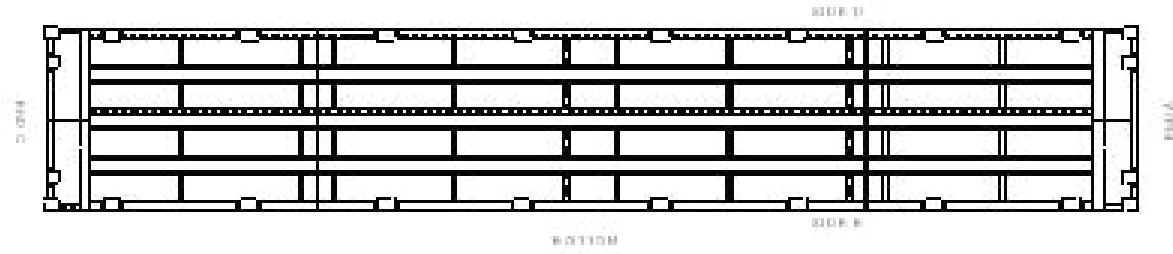
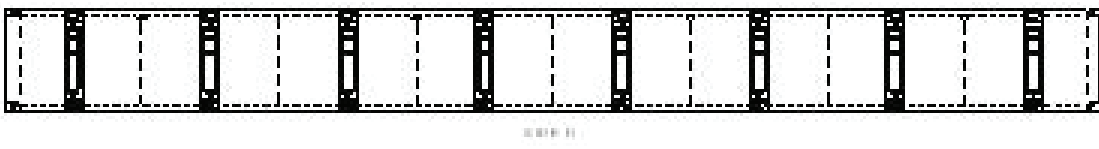
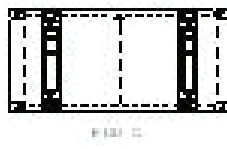
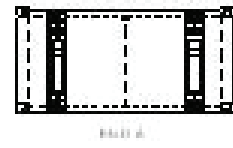
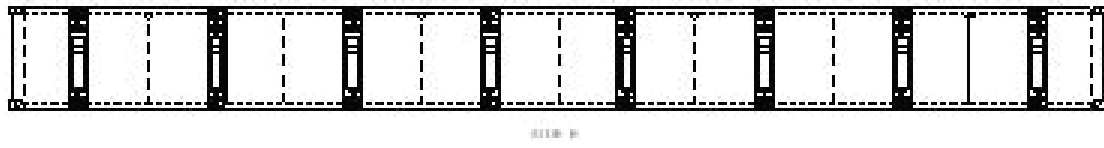
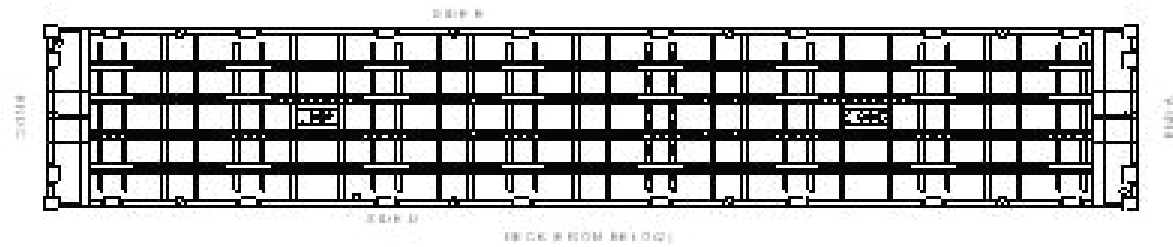

COMMENTS _____

ROBISHAW CENTER RAKE MODULE
MODULE SERIAL NO. _____ DATE _____

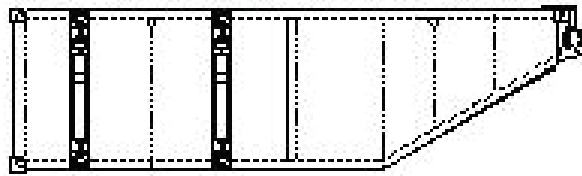

SIDE B

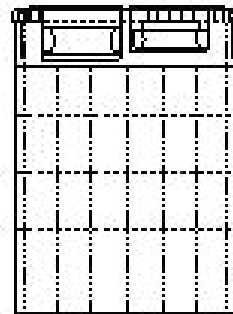

END C

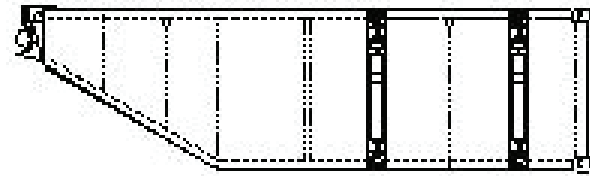

SIDE B

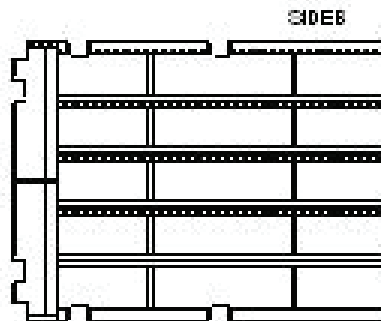

SIDE B

NO RE BOTTOM

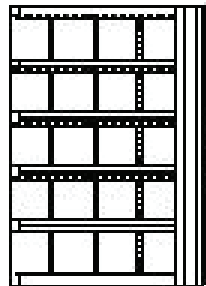

END C

OLD RE BOTTOM

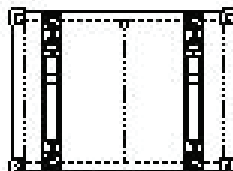

END A

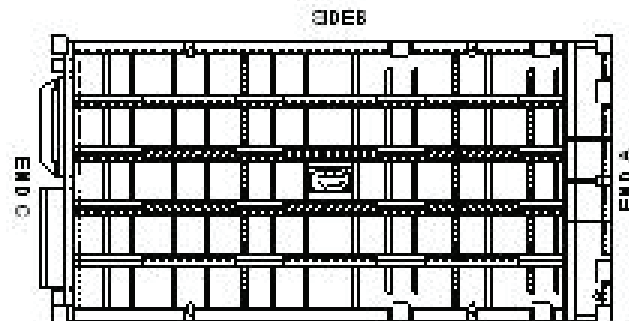

SIDE B

SIDE B

DECK (FROM BELOW)

COMMENTS _____

ROBISHAW LEFT RAKE MODULE

MODULE SERIAL NO. _____ DATE _____

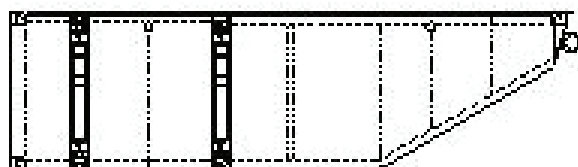

SIDE D

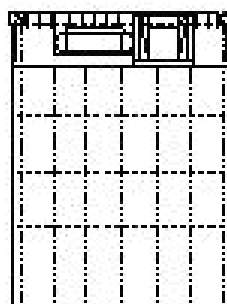

END C

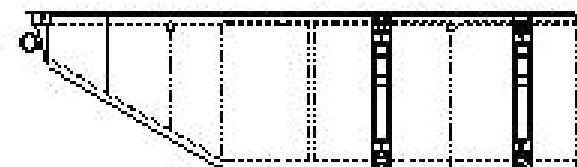

SIDE B

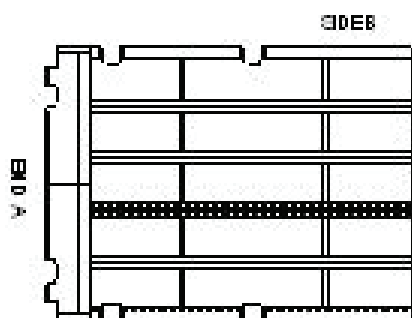

HORIZ. BOTTOM
SIDE B

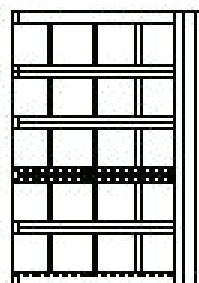

SIDE B BOTTOM
END C

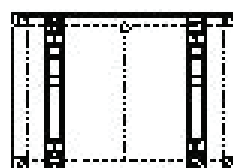

END A

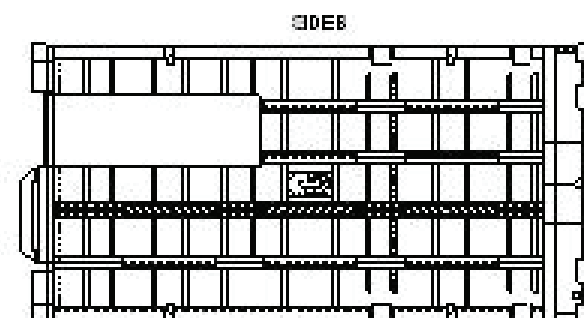

DECK (FROM BELOW)
SIDE B
END A

COMMENTS: _____

ROE SHAWRIGHT RAKE MODULE
MODULE SERIAL NO. _____ DATE: _____

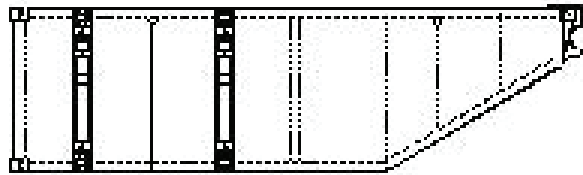

SIDE

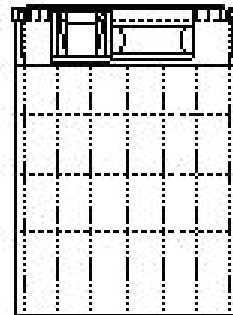

END C

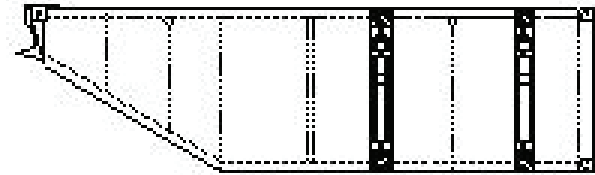

SIDE

SIDE

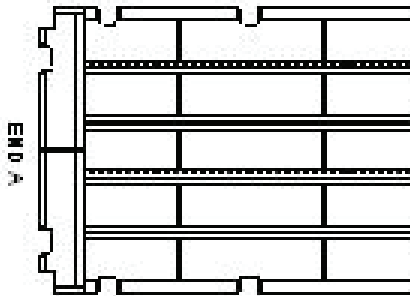

SIDE

HORIZ. BOTTOM

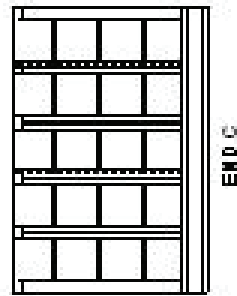

END C

SLOPE BOTTOM

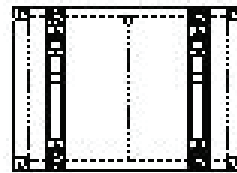

END A

SIDE

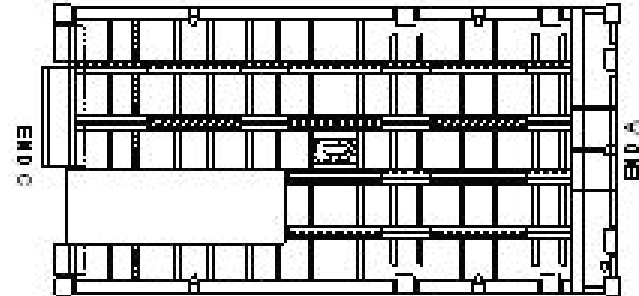

SIDE

DECK (FROM BELOW)

COMMENTS: _____

LAKE SHORE INTERMEDIATE MODULE
MODULE SERIAL NO. _____ DATE _____

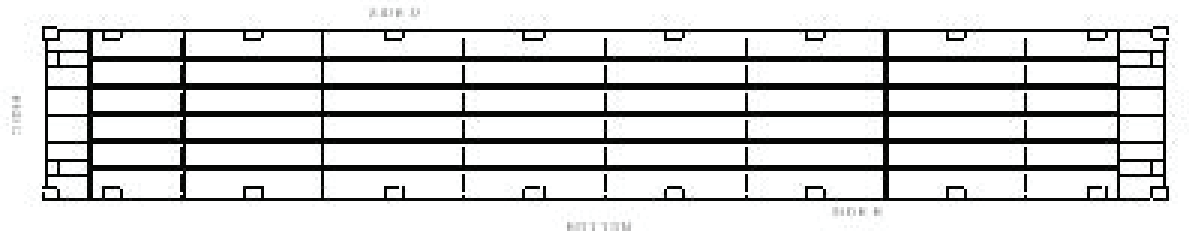
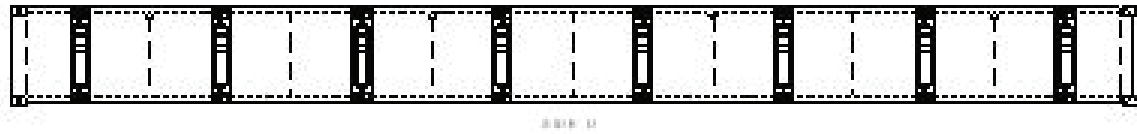
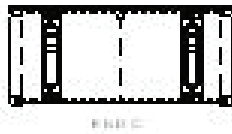
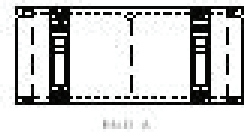
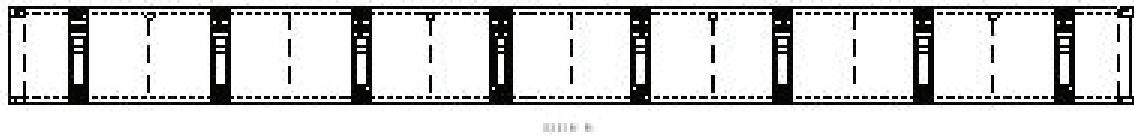
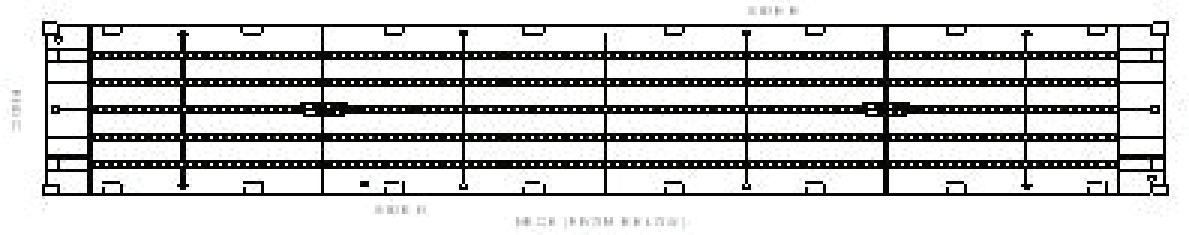

COMMENTS _____

LAKE SHORE CENTER RAKE MODULE
MODULE SERIAL NO. _____ DATE _____

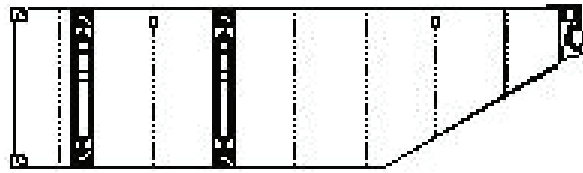

SIDE D

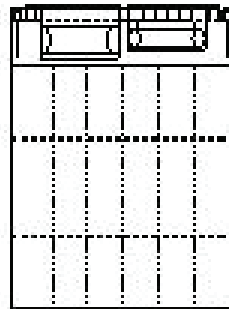

END C

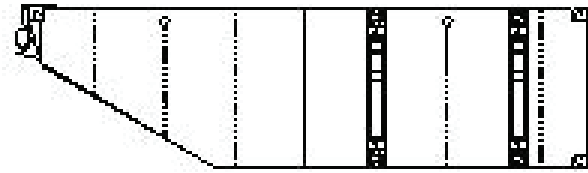

SIDE B

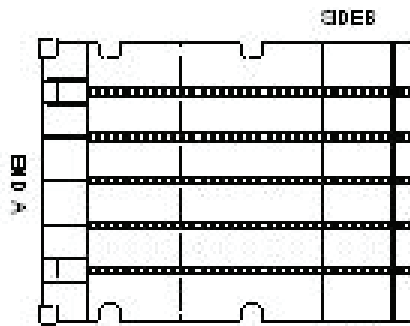

SIDE D

HORIZ. BOTTOM

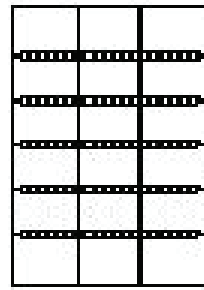

SLOPE BOTTOM

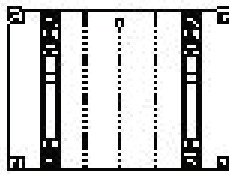

END A

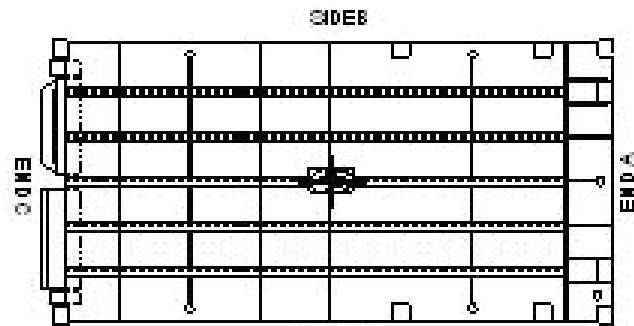

SIDE D

DECK (FROM BELOW)

COMMENTS: _____

LAKE SHORE LEFT RAKE MODULE
 MODULE SERIAL NO. _____ DATE _____

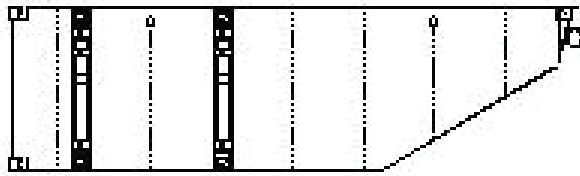

SIDE D

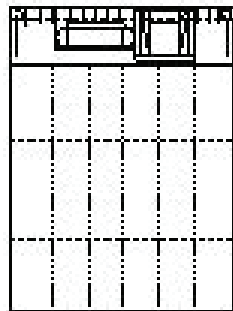

END C

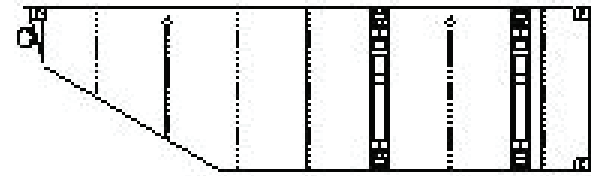

SIDE B

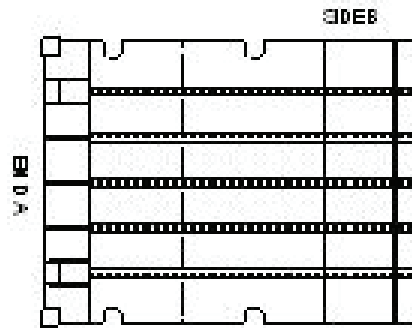

SIDE B

END B

SIDE D

HORE. BOTTOM

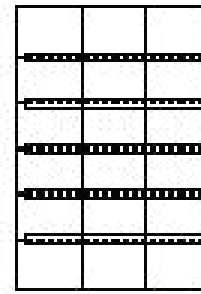

END C

SLOPE BOTTOM

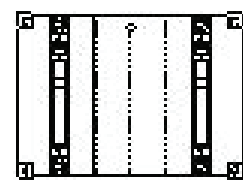

END A

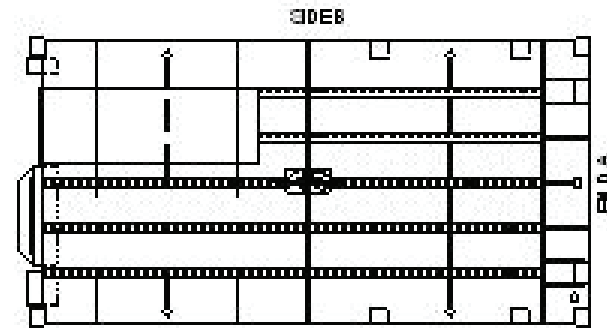

SIDE B

END A

SIDE D

DIRTY FROM BELOW

COMMENTS: _____

LAKE SHORE RIGHT RAKE MODULE
MODULE SERIAL NO. _____ DATE: _____

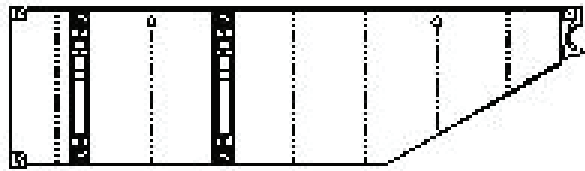

SIDE

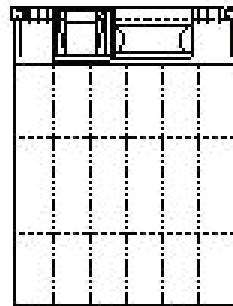

END C

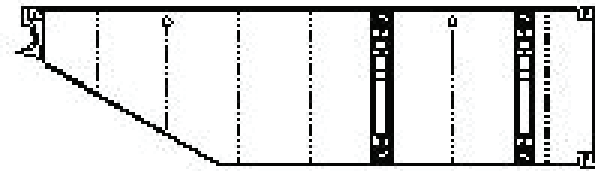

SIDE

SIDE

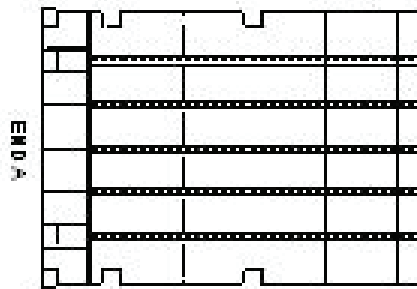

WOME

SIDE

HORIZ. BOTTOM

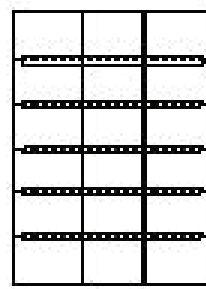

END C

SLOPE BOTTOM

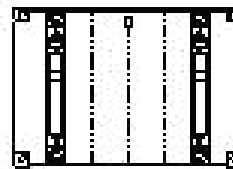

END A

SIDE

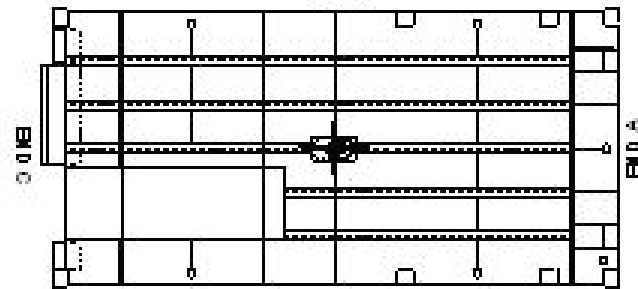

SIDE

END A

SIDE

DECK (FROM BELOW)

COMMENTS _____

RECOMMENDED CHANGES TO PUBLICATIONS AND BLANK FORMS For use of this form, see AR 25-30; the proponent agency is ODISC4.						Use Part II (reverse) for Repair Parts and Special Tool Lists (RPSTL) and Supply Catalogs/Supply Manuals (SC/SM).	DATE Date you filled out this form.
TO: <i>(Forward to proponent of publication or form) (Include ZIP Code)</i> AMSTA-LC-LMPP / TECH PUBS, TACOM-RI 1 Rock Island Arsenal Rock Island, IL 61299-7630						FROM: <i>(Activity and location) (Include ZIP Code)</i> Your mailing address	
PART I – ALL PUBLICATIONS (EXCEPT RPSTL AND SC/SM) AND BLANK FORMS							
PUBLICATION/FORM NUMBER TB 55-1945-205-10						DATE 31 July 2008	Title Guide to convention for Safe Containers/ Reinspection of Modular Causeway Systems
ITEM NO.	PAGE NO.	PARA-GRAPH	LINE NO. *	FIGURE NO.	TABLE NO.	RECOMMENDED CHANGES AND REASON (Provide exact wording of recommended changes, if possible).	
SAMPLE							
<i>*Reference to line numbers within the paragraph or subparagraph.</i>							
TYPED NAME, GRADE OR TITLE Your Name				TELEPHONE EXCHANGE/AUTOVON, PLUS EXTENSION		Signature Your Signature	

TO: (Forward direct to addressee listed in publication) AMSTA-LC-LMPP / TECH PUBS, TACOM-RI 1 Rock Island Arsenal Rock Island, IL 61299-7630	FROM: (Activity and location) (Include ZIP Code) Your address	DATE Date you filled out this form
--	---	--

PART II – REPAIR PARTS AND SPECIAL TOOL LISTS AND SUPPLY CATALOGS/SUPPLY MANUALS

PUBLICATION NUMBER TB 55-1945-205-10	DATE 31 July 2008	TITLE Guide to Convention for Safe Containers Reinspection of Modular Causeway Systems
--	-----------------------------	--

PAGE NO.	COLM NO.	LINE NO.	NATIONAL STOCK NUMBER	REFERENCE NO.	FIGURE NO.	ITEM NO.	TOTAL NO. OF MAJOR ITEMS SUPPORTED	RECOMMENDED ACTION
SAMPLE								

PART III – REMARKS (Any general remarks or recommendations, or suggestions for improvement of publications and blank forms. Additional blank sheets may be used if more space is needed.)

TYPED NAME, GRADE OR TITLE Your Name	TELEPHONE EXCHANGE/AUTOVON, PLUS EXTENSION	SIGNATURE Your Signature
--	---	------------------------------------

RECOMMENDED CHANGES TO PUBLICATIONS AND BLANK FORMS						Use Part II (reverse) for Repair Parts and Special Tool Lists (RPSTL) and Supply Catalogs/Supply Manuals (SC/SM).	DATE
For use of this form, see AR 25-30; the proponent agency is ODISC4.							
TO: (Forward to proponent of publication or form)(Include ZIP Code)						FROM: (Activity and location) (Include ZIP Code)	
AMSTA-LC-LMPP / TECH PUBS, TACOM-RI 1 Rock Island Arsenal Rock Island, IL 61299-7630							
PART I – ALL PUBLICATIONS (EXCEPT RPSTL AND SC/SM) AND BLANK FORMS							
PUBLICATION/FORM NUMBER						DATE	TITLE
TB 55-1945-205-10						31 July 2008	Guide to Convention for Safe Containers (CSC) Reinspection of Modular Causeway Systems ISOPAK
ITEM NO.	PAGE NO.	PARA-GRAPH	LINE NO. *	FIGURE NO.	TABLE NO.	RECOMMENDED CHANGES AND REASON (Provide exact wording of recommended changes, if possible).	
TYPED NAME, GRADE OR TITLE				<i>*Reference to line numbers within the paragraph or subparagraph.</i>			
				TELEPHONE EXCHANGE/AUTOVON, PLUS EXTENSION		SIGNATURE	

TO: (Forward direct to addressee listed in publication) AMSTA-LC-LMPP / TECH PUBS, TACOM-RI 1 Rock Island Arsenal Rock Island, IL 61299-7630	FROM: (Activity and location) (Include ZIP Code)	DATE
--	---	-------------

PART II – REPAIR PARTS AND SPECIAL TOOL LISTS AND SUPPLY CATALOGS/SUPPLY MANUALS

PUBLICATION NUMBER TB 55-1945-205-10				DATE 31 July 208			TITLE Guide to Convention for Safe Containers Reinspection of Modular Causeway Systems	
PAGE NO.	COLM NO.	LINE NO.	NATIONAL STOCK NUMBER	REFERENCE NO.	FIGURE NO.	ITEM NO.	TOTAL NO. OF MAJOR ITEMS SUPPORTED	RECOMMENDED ACTION

PART III – REMARKS (Any general remarks or recommendations, or suggestions for improvement of publications and blank forms. Additional blank sheets may be used if more space is needed.)

TYPED NAME, GRADE OR TITLE	TELEPHONE EXCHANGE/AUTOVON, PLUS EXTENSION	SIGNATURE
----------------------------	--	-----------

RECOMMENDED CHANGES TO PUBLICATIONS AND BLANK FORMS						Use Part II (reverse) for Repair Parts and Special Tool Lists (RPSTL) and Supply Catalogs/Supply Manuals (SC/SM).	DATE
For use of this form, see AR 25-30; the proponent agency is ODISC4.							
TO: (Forward to proponent of publication or form) (Include ZIP Code) AMSTA-LC-LMPP / TECH PUBS, TACOM-RI 1 Rock Island Arsenal Rock Island, IL 61299-7630						FROM: (Activity and location) (Include ZIP Code)	
PUBLICATION/FORM NUMBER TB 55-1945-205-10						DATE 31 July 2008	TITLE Guide to Convention for Safe Containers (CSC) Reinspection of Modular Causeway Systems ISOPAK
ITEM NO.	PAGE NO.	PARA-GRAPH	LINE NO. *	FIGURE NO.	TABLE NO.	RECOMMENDED CHANGES AND REASON (Provide exact wording of recommended changes, if possible).	
<i>*Reference to line numbers within the paragraph or subparagraph.</i>							
TYPED NAME, GRADE OR TITLE					TELEPHONE EXCHANGE/AUTOVON, PLUS EXTENSION		SIGNATURE

TO: (Forward direct to addressee listed in publication) AMSTA-LC-LMPP / TECH PUBS, TACOM-RI 1 Rock Island Arsenal Rock Island, IL 61299-7630	FROM: (Activity and location) (Include ZIP Code)	DATE
--	---	-------------

PART II – REPAIR PARTS AND SPECIAL TOOL LISTS AND SUPPLY CATALOGS/SUPPLY MANUALS

PUBLICATION NUMBER TB 55-1945-205-10				DATE 31 July 2008			TITLE Guide to Convention for Safe Containers Reinspection of Modular Causeway Systems	
PAGE NO.	COLM NO.	LINE NO.	NATIONAL STOCK NUMBER	REFERENCE NO.	FIGURE NO.	ITEM NO.	TOTAL NO. OF MAJOR ITEMS SUPPORTED	RECOMMENDED ACTION

PART III – REMARKS *(Any general remarks or recommendations, or suggestions for improvement of publications and blank forms. Additional blank sheets may be used if more space is needed.)*

--

TYPED NAME, GRADE OR TITLE	TELEPHONE EXCHANGE/AUTOVON, PLUS EXTENSION	SIGNATURE
----------------------------	--	-----------

RECOMMENDED CHANGES TO PUBLICATIONS AND BLANK FORMS For use of this form, see AR 25-30; the proponent agency is ODISC4.	Use Part II (reverse) for Repair Parts and Special Tool Lists (RPSTL) and Supply Catalogs/Supply Manuals (SC/SM).	DATE
---	---	------

TO: (Forward to proponent of publication or form)(Include ZIP Code) AMSTA-LC-LMPP / TECH PUBS, TACOM-RI 1 Rock Island Arsenal Rock Island, IL 61299-7630	FROM: (Activity and location) (Include ZIP Code)
---	--

PART I - ALL PUBLICATIONS (EXCEPT RPSTL AND SC/SM) AND BLANK FORMS

PUBLICATION/FORM NUMBER TB 55-1945-205-10	DATE 31 July 2008	TITLE Guide to Convention for Safe Containers (CSC) Reinspection of Modular Causeway Systems ISOPAK
--	----------------------	--

ITEM NO.	PAGE NO.	PARA-GRAPH	LINE NO. *	FIGURE NO.	TABLE NO.	RECOMMENDED CHANGES AND REASON (Provide exact wording of recommended changes, if possible).

TYPED NAME, GRADE OR TITLE	*Reference to line numbers within the paragraph or subparagraph.	TYPED NAME, GRADE OR TITLE
	TELEPHONE EXCHANGE/AUTOVON, PLUS EXTENSION	SIGNATURE

TO: (Forward direct to addressee listed in publication) AMSTA-LC-LMPP / TECH PUBS, TACOM-RI 1 Rock Island Arsenal Rock Island, IL 61299-7630	FROM: (Activity and location) (Include ZIP Code)	DATE
--	---	-------------

PART II – REPAIR PARTS AND SPECIAL TOOL LISTS AND SUPPLY CATALOGS/SUPPLY MANUALS

PUBLICATION NUMBER TB 55-1945-205-10					DATE 31 July 2008		TITLE Guide to Convention for Safe Containers (CSC) Reinspection of Modular Causeway Systems	
PAGE NO.	COLM NO.	LINE NO.	NATIONAL STOCK NUMBER	REFERENCE NO.	FIGURE NO.	ITEM NO.	TOTAL NO. OF MAJOR ITEMS SUPPORTED	RECOMMENDED ACTION

PART III – REMARKS (Any general remarks or recommendations, or suggestions for improvement of publications and blank forms. Additional blank sheets may be used if more space is needed.)

TYPED NAME, GRADE OR TITLE	TELEPHONE EXCHANGE/AUTOVON, PLUS EXTENSION	SIGNATURE
----------------------------	--	-----------

By Order of the Secretary of the Army:

GEORGE W. CASEY, JR.
General, United States Army
Chief of Staff

Official:

JOYCE E. MORROW
Administrative Assistant to the
Secretary of the Army
0816204

Distribution:

To be distributed in accordance with the initial distribution number (IDN) 344921 requirements for TM 55-1945-205-10.

The Metric System and Equivalents

Linear Measure

1 centimeter = 10 millimeters = .39 inch
 1 decimeter = 10 centimeters = 3.94 inches
 1 meter = 10 decimeters = 39.37 inches
 1 dekameter = 10 meters = 32.8 feet
 1 hectometer = 10 dekameters = 328.08 feet
 1 kilometer = 10 hectometers = 3,280.8 feet

Liquid Measure

1 centiliter = 10 milliliters = .34 fl. ounce
 1 deciliter = 10 centiliters = 3.38 fl. ounces
 1 liter = 10 deciliters = 33.81 fl. ounces
 1 dekaliter = 10 liters = 2.64 gallons
 1 hectoliter = 10 dekaliters = 26.42 gallons
 1 kiloliter = 10 hectoliters = 264.18 gallons

Weights

1 centigram = 10 milligrams = .15 grain
 1 decigram = 10 centigrams = 1.54 grains
 1 gram = 10 decigrams = .035 ounce
 1 dekagram = 10 grams = .35 ounce
 1 hectogram = 10 dekagrams = 3.52 ounces
 1 kilogram = 10 hectograms = 2.2 pounds
 1 quintal = 100 kilograms = 220.46
 1 metric ton = 10 quintals = 1.1 short tons

Sqaure Measure

1 sq. centimeter = 100 sq. millimeters = .155 sq. inch
 1 sq. decimeter = 100 sq. centimeters = 15.5 sq. inches
 1 sq. meter (centare) = 100 sq. decimeters = 10.76 sq. feet
 1 sq. dekameter (are) = 100 sq. meters = 1,076.4 sq. feet
 1 sq. hectometer (hectare) = 100 sq. dekameters = 2.47 acres
 1 kilometer = 100 sq. hectometers = .386 sq. mile

Cubic Measure

1 cu. centimeter = 1000 cu. millimeters = .06 cu. inch
 1 cu. decimeter = 1000 cu. centimeters = 61.02 cu. inches
 1 cu. meter = 1000 cu. decimeters = 35.31 cu. feet

Approximate Conversion Factors

<i>To change</i>	<i>To</i>	<i>Multiply by</i>	<i>To change</i>	<i>To</i>	<i>Multiply by</i>
inches	centimeters	2.540	ounce-inches	newton-meters	.007062
feet	meters	.305	centimeters	inches	.394
yards	meters	.914	meters	feet	3.280
miles	kilometers	1.609	meters	yards	1.094
square inches	square centimeters	6.451	kilometers	miles	.621
square feet	square meters	.093	square centimeters	sqaure inches	.155
square yards	square meters	.836	square meters	square feet	10.764
square miles	square kilometers	2.590	square meters	square yards	1.196
acres	square hectometers	.405	square kilometers	square miles	.386
cubic feet	cubic meters	.028	square hectometers	acres	2.471
cubic yards	cubic meters	.765	cubic meters	cubic feet	35.315
fluid ounces	milliliters	29.573	cubic meters	cubic yards	1.308
pints	liters	.473	milliliters	fluid ounces	.034
quarts	liters	.946	liters	pints	2.113
gallons	liters	3.785	liters	quarts	1.057
ounces	grams	28.349	liters	gallons	.264
pounds	kilograms	.454	grams	ounces	.035
short tons	metric tons	.907	kilograms	pounds	2.205
pound-feet	newton-meters	1.356	metric tons	short tons	1.102
pounds-inches	newton meters	.11296			

Temperature (Exact)

° F Fahrenheit 5/9 (after Celsius ° C
 temperature subtracting 32) temperature

PIN 084919-000